

# Designing a Clean, Quiet, Fuel Efficient High Performance Two-Stroke Flex Fuel Snowmobile

Hunter Hitzemann, Jason Plutz, Joe Plutz, Brennan Seeliger, Shane O'Rourke  
University of Wisconsin-Platteville

David Kunz  
Mech. Eng. Dept., University of Wisconsin-Platteville

Copyright © 2010 SAE International

## ABSTRACT

The University of Wisconsin-Platteville (UW-P) Clean Snowmobile Team has successfully designed and constructed a quiet, environmentally friendly, high performance snowmobile for the 2010 Society of Automotive Engineers (SAE) Clean Snowmobile Challenge (CSC). Built on a 2008 Ski-Doo REV-XP chassis, this machine features a 594 cc semi-direct-injection (SDI) two-stroke engine. The Boondocker Performance fuel management system used to decrease exhaust emissions and improve fuel economy maintains near stock engine power while allowing operation on any blend of gasoline and ethanol between E20 and E29. The emissions output is further reduced by utilizing a pre-burn catalyst system customized for this engine by Tikka Race. A modified expansion chamber, muffler system, and the addition of sound absorbing material are respectively used to reduce exhaust and engine compartment noise. Finally, a number of additional improvements have been made to the driveline and chassis to increase efficiency and diminish noise. These modifications achieved UW-P's reliability, efficiency, and noise goals, as testing done prior to competition showed the snowmobile getting 14.1 mpg (6 km/L) on E25 ethanol fuel, creating 116 hp (88 kW), and emitting 80% less HC when compared to stock emissions numbers.

## INTRODUCTION

The modern day recreational snowmobile evolved from a 1958 design by Joseph-Armand Bombardier. Bombardier began commercial production and marketing of the Ski-Doo snowmobile in 1959. Public interest in the small snowmobiles grew quickly, and suddenly a new winter sport was born, centered in Quebec, Canada. In the first year, Bombardier sold 225 Ski-Doos. Looking ahead 50 years, there are now four primary manufacturers of snowmobiles, with total 2009 sales reaching 147,066 units worldwide, and 61,593 of those sales taking place in the U.S [1].

Traditionally, snowmobiles have been plagued with poor fuel economy, high emissions, and high levels of noise pollution. The environmental impact of these machines became such a concern that the federal government banned snowmobile usage in national parks in the year 2000. In response to this ban, the Society of Automotive Engineers (SAE), along with the Environmental Protection Agency (EPA), National Parks Service (NPS) and the Department of Energy (DoE), created the Clean Snowmobile Challenge. The CSC is an engineering design competition among colleges to develop clean, quiet, fuel efficient alternatives to conventional two-stroke

snowmobiles. Competition entries are redesigned versions of original equipment manufacturer (OEM) snowmobiles, and are tested on design strategies, emissions (CO, HC, and NO<sub>x</sub>), fuel economy, noise, rider comfort, handling, acceleration, and cold starting abilities [2]. They are expected to be reliable, able to run efficiently on any blend of ethanol/gasoline mixture between E-20 and E-29, and yet be marketable within the current snowmobile industry by maintaining consumer-acceptable levels of performance. Students will showcase their re-designed snowmobiles March 15-20, 2010, at the Keweenaw Research Center in Michigan's Upper Peninsula.

Today, U.S. national parks are operating under a temporary winter use plan, which restricts the number of snowmobiles entering the parks every day. Those wishing to enter park areas are required to have Best Available Technology (BAT), which are the cleanest and quietest group of commercially available snowmobiles. The EPA has also issued a required reduction on snowmobile emissions. Consisting of three phases, the regulations include a 50 % reduction by 2010, and a 70 % reduction by 2012. Specific emission limits can be seen below in Table 1.

**Table 1: Exhaust Emission Standards for Snowmobiles [3]**

Model Year	Phase In % of sales	Emissions (g/kW-hr)		
		HC	HC+NO <sub>x</sub>	CO
2007-2009	100	100	-	275
2010-2011	100	75	-	275
2012 & later	100	75	90	275

These restrictions have forced snowmobile manufacturers to explore and rapidly develop new technology. Some companies have shifted their focus to the four-stroke engine, which when compared to an equivalent two-stroke engine is much quieter, more fuel efficient, and emits fewer HC. Other companies have further developed two-stroke technology, implementing advanced fuel delivery and management systems. These highly sophisticated two-strokes are smaller, lighter, have fewer moving parts, and emit less NO<sub>x</sub> compared to equivalent four-stroke engines.

DESIGN OBJECTIVES-To be one of the elite teams to compete in the 2010 Clean Snowmobile Challenge, the University of Wisconsin-Platteville has re-engineered the best two-stroke technology the snowmobile industry has to offer. With the 2010 CSC main competition objective being to improve fuel economy the team's main goal was making a more efficient snowmobile. Teams will compete in two different events to measure fuel economy. The first will coincide with the 100 mile (160 km) endurance event, where 100 points will be awarded to teams that successfully complete the mileage requirement while maintaining the 45 mph (72 kph) speed requirement. They will then receive additional "performance points" for their fuel economy compared to the rest of the field based on equation (1) [2]:

$$\text{Team Score} = 100 * \frac{\left[ \left( \frac{G_{\max}}{G_{\text{team}}} \right)^2 - 1 \right]}{\left[ \left( \frac{G_{\max}}{G_{\min}} \right)^2 - 1 \right]} \quad (1)$$

Where G is the number of gallons of fuel consumed.

Fuel economy is also measured during an in-service emissions event. Scores between 0 and 50 are awarded according to equation (2) [2].

$$\text{Team Score} = 50 * \left[ \frac{\left( \frac{\text{FE max}}{\text{FE team}} \right)^2 - 1}{\left( \frac{\text{FE max}}{\text{FE min}} \right)^2 - 1} \right] \quad (2)$$

Where FE is the Fuel Economy measured in the event.

The team's second goal was to reduce HC and CO emissions while running ethanol blended fuel. Scoring for this event is based on an exclusive in-service emission test, followed by a five-mode test cycle as published by SwRI [2, 4]. Table 2 shows the speeds, loads, and weighing factors for the five-mode test.

**Table 2: The five-mode snowmobile test procedure used by the EPA and NPS.**

Mode Point	Speed [% of Rated]	Torque [% of Rated]	Weighting [%]
1	100	100	12
2	85	51	27
3	75	33	25
4	65	19	31
5	Idle	0	5

An EPA snowmobile emission number E is determined by using the results from Table 2 in Equation (3) [5]. A minimum E score of 100 is required to meet the corporate 2012 snowmobile emissions standards. The average weighted emissions for (UHC+NO<sub>x</sub>) and CO cannot respectively exceed 90 and 275 (g/kW-hr). One-hundred points are assigned to teams achieving the minimum composite score, with additional points given to teams exceeding the minimum composite score, based on relative performance. To meet the stricter NPS standards, a minimum emission number E of 170 is required, where UHC+NO<sub>x</sub> and CO emissions cannot respectively exceed 15 and 120 (g/kW-hr) [6].

$$E = \left[ 1 - \frac{(\text{HC} + \text{NO}_x) - 15}{150} \right] * 100 + \left[ 1 - \frac{\text{CO}}{400} \right] * 100 \quad (3)$$

The in-service emissions event was new for the 2009 CSC, and returned as a viable event for 2010. The goal of the event is to determine the total gaseous emission the snowmobile produces during trail riding. Unlike the five-mode test, the event is designed to measure total emissions. Competition organizers operate the snowmobiles on a 3 mi (4.83 km) course while an emission measurement trailer collects HC, CO, CO<sub>2</sub>, and NO<sub>x</sub> produced. Zero to 50 points are assigned to teams based on total grams of emissions relative to the cleanest and dirtiest competitors [2].

Noise emissions were also a high priority for the team, as both objective and subjective noise events take place at competition. The objective noise test procedure follows the SAE J192 recommended practice. During the test, sound pressure created by the sled cannot exceed 78 dB, which is the standard set by the International Snowmobile Manufacturers Association (ISMA). Teams receive 75 points for having a sound pressure less than or equal to 78 db, and are eligible to receive more points both based on how far below the standard they are, as well as from a separate subjective noise test.

For the subjective noise test, recordings of the snowmobiles taken during the J192 test are played back to a jury of CSC volunteers. One-hundred fifty points are awarded to the team with the most favorable subjective noise, while the least favorable score receives zero points.

Achieving the three previous goals would be a hollow victory if the cost, performance, or comfort of the snowmobile were unreasonably compromised. Although they are not the main focus of the CSC, teams compete in acceleration, subjective handling, and objective handling events in order to quantify performance and handling characteristics of their snowmobiles. In order to pass the acceleration event, the snowmobiles need to complete the 500 ft (152 m) course in less than 12 seconds. Each team gets two attempts, and the faster time is used for scoring. Fifty points are awarded to the fastest team, while the other teams receive points based on their relative performance. The first handling event objectively evaluates the agility and maneuverability of each competition snowmobile. A team member completes individually timed consecutive laps on a designated obstacle course. The fastest team receives 75 points. For the subjective handling event, professional snowmobile riders will drive each competition snowmobile through a course designed to evaluate ride quality. Fifty points will be awarded to the winning team, with the other teams receiving points based on their relative scores.

A cold start test is also performed at competition. In order to pass the event and receive 50 points, snowmobiles need to start within 20 seconds without the aid of starting fluids and move 100 ft (30.5 m) within the first two minutes. An oral presentation and static display event are performed by student teams in order to explain how their particular solution meets the needs of the environment, the dealer, and the consumer.

Prior to the competition, a technical design report is written and submitted by the students. This report explains the challenges faced and modifications performed during the design and construction period of the competition snowmobile. The following paper describes UW-Platteville's design strategy. The first section addresses the chassis and engine selection process. The second describes modifications to the snowmobile's engine, driveline, and chassis. The third and fourth sections focus on emissions and noise reduction techniques. The paper itself addresses the combined modifications employed to optimize the aforementioned technologies, respectively. Finally, the paper summarizes the cumulative cost corresponding to a comparable stock production snowmobile.

## **MARKET SURVEY**

Practicality and simplicity are the guiding principles for UW-Platteville's clean snowmobile design. In order to successfully market to current snowmobile consumers, the team conducted a random survey consisting of 105 snowmobile enthusiasts located in the Northern U.S. and Canada. This allowed the team to determine what qualities consumers deemed most important. The poll, which was conducted on the HardcoreSledder (HCS) forum, asked volunteers to rank the attributes important to them when considering the purchase of a new snowmobile. Emissions, fuel economy and performance/handling were the characteristics voters were asked to rate based on importance. The results, shown in Figure 1, display that performance/handling influence a buyer noticeably more than either fuel economy or emissions.

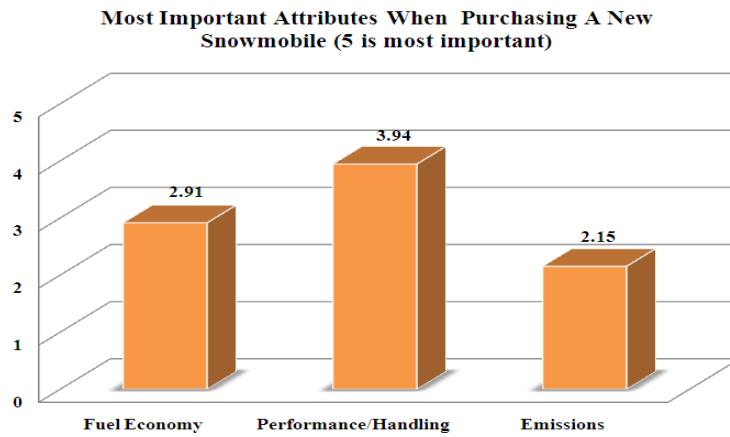

Figure 1: Results from a survey conducted on the HardcoreSledder website showing performance/handling is the most important attribute when purchasing a new snowmobile.

Snowmobile industry sales numbers for the 2007 model year further verify the poll results. Ski-Doo, a division of, Bombardier Recreational Products (BRP), exclusively builds high performance, lightweight two-stroke snowmobiles that have excellent handling and performance characteristics. As seen in Figure 2, Ski-Doo showed superior dominance in the market with 12.5% more total sales than Polaris, Arctic Cat or Yamaha [7].

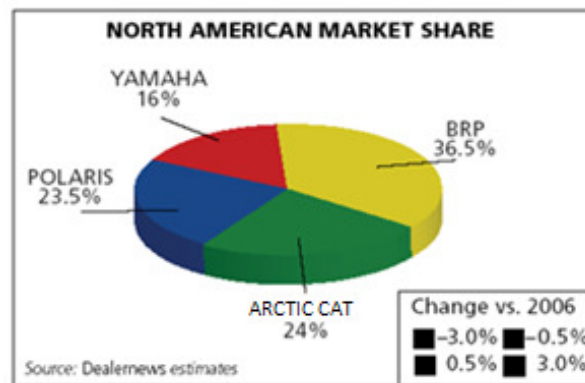

Figure 2: 2007 industry market share in the U.S. between the four snowmobile manufacturers.

## ENGINE SELECTION

Given that the market survey results showed that consumers demand a snowmobile that excels in performance and handling areas, the team searched for engines that had superior power to weight ratios. To assist in the engine selection process, the team conducted a second survey on HardcoreSledder, which had 120 volunteers share what engine type their current snowmobile has, and the engine option they would most likely purchase as their next snowmobile. The options listed in the poll included: two-stroke carbureted, two-stroke fuel injected, four-stroke carbureted and four-stroke fuel injected. As seen in Figure 3, 48% of the participating volunteers stated their next snowmobile would be powered by a two-stroke, fuel injected engine.

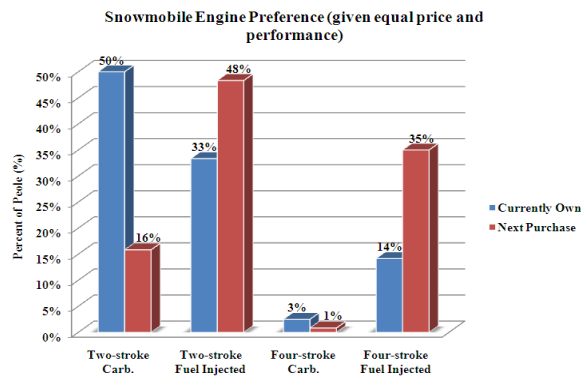

Figure 3: Results from a survey conducted on the Hardcoresledder website showing enthusiasts would prefer a two stroke fuel injected engine as their next snowmobile.

Other than 2007, in which a direct injected two-stroke proved to be more efficient, the past CSC competitions have proven a four-stroke engine can be used in snowmobiles to produce a clean, quiet, fuel efficient snowmobile [8, 9, 10, 11, 12, 13, 14]. Snowmobile emissions testing, performed by Southwest Research Institute (SwRI), also proves this point by stating that commercially available four-strokes “...emit 98-95 percent less HC, 85 percent less CO, and 90-96 percent less PM” than conventional two stroke snowmobile engines [15]. However, the demand for two-stroke powered snowmobiles is still very high due to their excellent power-to-weight ratio, and new technology continues to emerge.

With the recent development of semi-direct fuel injection, two-stroke snowmobiles have become capable of achieving fuel economy that matches or exceeds that of current production four-stroke snowmobiles, while still maintaining their light weight [11]. However, from an emissions standpoint, SDI two-strokes are still subpar in comparison to four-stroke engines. Table 1 shows the difference in emissions produced and fuel economy between carbureted two-stroke, electronic fuel injection (EFI) four-stroke, and semi-direct injection two-stroke snowmobile engines.

**Table 3: Emissions and fuel economy of two and four-stroke snowmobiles at CSC [9, 10, 11].**

CSC Year Engine Type	CO [g/kW-hr]	UHC [g/kW-hr]	NOx [g/kW-hr]	Fuel Econ. [MPG]
'03 Two-Stroke Carbureted*	319.94	125.50	0.73	8.7
'04 Four-Stroke EFI*	99.84	11.48	23.33	15.3
'05 Two-Stroke SDI*	215.38	63.53	2.39	19.1
* Indicates snowmobile was control snowmobile				

The high specific outputs that exist in significantly less mechanically complex two-stroke engines allows for them to have higher performance qualities than comparable four-strokes. These higher performance qualities also allow for a more suitable torque curve for the belt-type continuously variable transmission (CVT) currently used in the snowmobile industry [15].

## FINAL ENGINE CHOICE

Taking into account the previous information and the apparent potential to vastly improve emissions over production two-stroke engines, the Wisconsin-Platteville team decided to build a clean, quiet, high performance two stroke powered snowmobile. The most important part of the teams design was to maintain the engine's simplicity, low cost and excellent power-to-weight ratio while methodically reducing emissions and increasing fuel economy.

The engine the Platteville Clean Snowmobile Team decided to modify was a loop scavenged, semi-direct injection reed valve, 594 cubic centimeter (cc) Rotax engine. This engine is factory equipped with a tuned pipe and Rotax's Electronic Automatic Variable Exhaust (eR.A.V.E.) system.

The Wisconsin-Platteville team chose this engine for multiple reasons, first being its compliance to competition guidelines, its performance characteristics indicative of two-stroke snowmobiles, and its readily available manufactured parts.

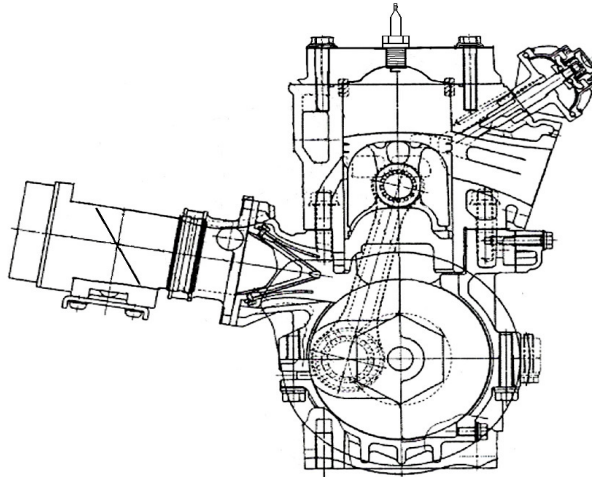

Figure 4: Cross section of a two-stroke engine similar to the one used by UW-P [16].

**Table 4: Rotax Engine Specifications**

Engine Type	Two-Stroke
Engine Details	Liquid-cooled, eR.A.V.E.
Cylinders	2
Displacement	594.4 cc
Bore x Stroke (mm)	72 x 73
Exhaust	Single
Fueling	Electronic SDI

## CHASSIS SELECTION

The University of Wisconsin-Platteville Clean Snowmobile Team has selected the 2008 Rev-XP chassis, as a base for the 2010 competition. In 2008 BRP moved the jackshaft above the tunnel on the Rev-XP chassis, allowing for additional foot clearance in comparison to its predecessor, the 2007 Rev. This additional room

allows for a wider variety of riding styles, which allows the rider better control and comfort. This is in addition to being lightweight and being available stock with the selected engine. Note the secondary clutch moved up and forward, making room for the rider's foot in the figure below.



Figure 5: Red outline shows the riding position and layout of the Rev, blue outline shows the Rev-XP [17].

## SYSTEM MODIFICATIONS

### ENGINE

Due to the naturally aspirated, twin-cylinder, Rotax 600 H.O. SDI's high power output and excellent reliability in stock configuration, the team concluded that the internal components of the engine need not be modified for the Clean Snowmobile Challenge.

### FUEL SYSTEM

A requirement of this year's competition is to have the snowmobile run on a fuel mixture of E20 through E29 fuel. These fuel mixtures have shown to have an increase in fuel mileage in automobiles [18]. Running these mixtures meant a new fuel system conversion was needed. This additional fuel is accomplished through an increased pulse duration and intensity of the injectors. After compiling previous year's knowledge, with additional research, the team decided that the best and most effective way to calibrate the fuel delivery system was to use a Boondocker<sup>®</sup> EFI fuel management system. The Boondocker control box allows fuel adjustment in seven different RPM ranges as well as low, mid, and high throttle positions. A five button interface allows for programming adjustments without the use of any additional hardware. The Boondocker control box is relatively inexpensive in comparison to other fuel management systems and is far more user friendly. The simple controls of this system can be seen in Figure 6 below [19].



Figure 6: Boondocker<sup>®</sup> EFI fuel management system.

In Platteville, Wisconsin, the only blends of fuel sold are E10, E25 and E85. With the guidelines of the competition requiring the engine to be able to run on any blend of fuel from E20 to E29, the engine was tuned on E25 due to the limited fuel blends offered in the area. Using the Boondocker EFI fuel management system, the engine was tuned to stoichiometric Air Fuel Ratio (sAFR) using an oxygen sensor in the exhaust pipe. In order to accurately tune the engine for high and low load scenarios, the proper Air Fuel Ratio (AFR) equilibrium needed to be calculated. Burning pure ethanol would reach equilibrium at an AFR of 9:1, while gasoline has an AFR of 14.7:1. To calculate the effective AFR, with a specific mixture of gasoline and ethanol, equation 4 was used:

$$\text{sAFR} = [(\% \text{ of additive} * \text{sAFR additive}) + (90 - \% \text{ of additive}) * (\text{sAFR of gas})] \left( \frac{1}{100} \right) \quad (4)$$

For example, the stoichiometric air-fuel ratio for E25 calculated from equation 4=13.2186:1.

Using this new air fuel ratio of 13.22:1 for stoichiometric equilibrium, a new baseline AFR at wide open throttle (WOT) can be calculated. After a dyno sweep was made on a stock Rotax 600 SDI, the baseline AFR at WOT was found to be 12.5:1. To find the target AFR at WOT for E25, the following equation was used:

$$\text{Target AFR} = \frac{(\text{Target AFR at WOT on gas}) * (\text{sAFR of E25})}{(\text{sAFR of gas})} \quad (5)$$

The new target AFR at wide open throttle is found to be 11.24:1, and compared to the target on gasoline shows a required increase of fuel delivery by 10%.

## CHASSIS AND BODY

The chassis of the 2008 Ski Doo Rev-XP is solid and lightweight, providing a strong platform to build the remainder of the snowmobile. For these reasons the University Wisconsin-Platteville CSC Team decided to leave the chassis in stock form.

The body panels are constructed of a lightweight plastic with foam placed inside for sound dampening. The temperatures reached by the catalyst are much too high for the plastic to withstand, so a more substantial material was needed to endure the temperatures exceeding 538° C. Aluminum was found to be the solution by the team. This material was chosen because of its balance between a high melting point, light weight, and heat transfer rate. The catalyst produces a substantially larger amount of heat than the stock silencer, therefore ventilation was needed. Aluminum mesh was placed over the catalyst to provide adequate airflow and ventilation.

## TRACK/SUSPENSION

To help increase driveline efficiency, the stock seven inch diameter track tensioning wheels were replaced with CNC billet aluminum ten inch diameter rear wheels, as seen on the left in Figure 7. The larger diameter wheels reduce the angular acceleration of the track by giving it a wider radius upon which to change direction. To compensate for the larger diameter wheels, the team decided to purchase two tracks: both are 128 inches in length and have pitches of 2.52. The pitch of the stock Ski-Doo track is 2.86. The team then purchased a set of CNC milled ten tooth drivers to replace the stock eight inchers, with a pitch of 2.52 to match the 128 inch tracks purchased. Again, a bigger radius allows for a longer amount of time to change direction, reducing the angular

acceleration. The effective drive ratio between the stock 8 tooth 2.86 pitch and a 9 tooth 2.52 pitch were calculated, and found to be nearly identical.

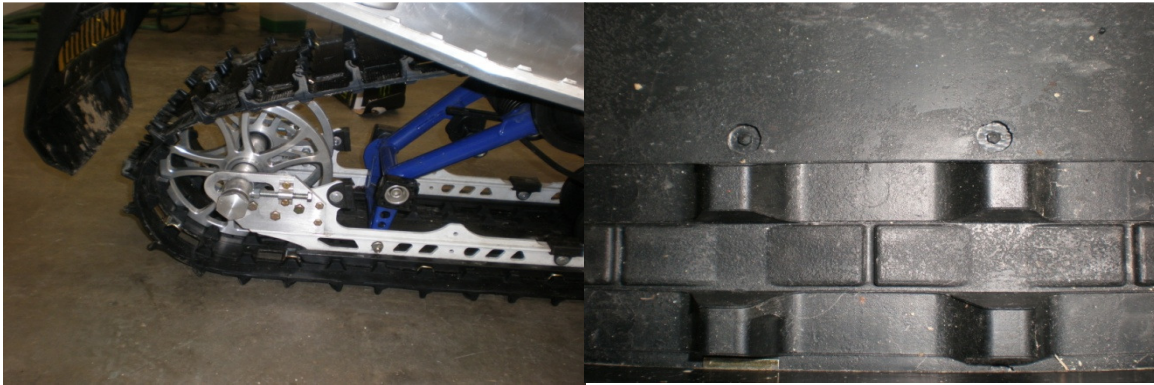

Figure 7: Ten inch CNC wheels with 128 inch track (left), quiet track ramps on the 13.5"x1"x128" track (right)

Driveline efficiency was measured by connecting an eight amp electric drill to the jackshaft of the snowmobile, while an ammeter was connected to the drill and used to measure the amount of current drawn to turn the driveline system. The first driveline test was conducted on the stock Ski-Doo setup, with 6 in bogey wheels, 7 in rear wheels, 8 tooth 2.86 in pitch drivers, and a 15"x1"x120" track weighing 31 lbs. The drill pulled 6.5 amps for this setup. The second test was carried out with a 15"x1.25"x128" track weighing 37 lbs, four 10 in rear wheels, and 2.52 in pitch 10 tooth drivers. This time the drill pulled 5.3 amps. The final test was conducted with a 13.5"x1"x128" track weighing 34 lbs, two 10 in rear wheels, and 10 tooth drivers. In this final test, the drill pulled 4.3 amps. Using the equation below, we determined that to turn the track at a low constant rpm, the horsepower used was .663 hp. By our calculations using equation 6 we found that the 13.5"x1"x128" track is the most efficient, requiring a mere 66% of the power the stock track, wheels, and drivers needs to be spun at the same speed.

$$\text{Horsepower Lost} = (115 \text{ Volts}) * (\text{Amps}) \left( 0.001341 \frac{\text{Hp}}{\text{Watts}} \right) \quad (6)$$

The efficiency of this setup was further confirmed by three back-to-back 50 mile trail mileage runs performed with (first) the stock track, wheels and drivers, (second) the ten inch wheels, ten tooth drivers, and 15"x1.25"x128" quiet track, and finally with the 13.5"x1"x128" quiet track. The vehicle used to test the scenario was UW-P's 2009 Ski-Doo 600 E-TEC, which has an identical chassis and suspension system to the team's 2008 Ski-Doo 600 SDI. The stock configuration run resulted in an average of 14 mpg. After bolting the new track, drivers, and wheels in place, the machine was sent out for another 50 mile loop. 21 mpg was recorded during this loop. However, after bolting the 13.5"x1"x128" track in and completing the final 50 mile loop, 22 mpg was recorded. Fuel mileage demonstrated over 50% improvement. The trail mileage test results assure that the static drill test performed was indeed accurate, and that our 13.5"x1"x128" track equipped with the large wheels and drivers is indeed the most efficient of the three setups.

The advantages of our longer, slightly narrower track don't just stop with efficiency however. An immediate improvement in ride quality could be felt, as the longer track tended to bridge the bumps and terrain much better than the shorter stock track. There was also more available traction with the longer track, as the footprint on the snow is larger than stock. The ramps placed on the track in figure 7 help reduce chatter and vibration caused from the idler wheels contacting the fiberglass rods spanning the track, ultimately reducing noise. Finally, with

a 1.5" narrower track the rotating mass is further centralized, yet again explaining and improving our gain in efficiency.

## EMISSIONS

Over the years many design modifications have been made to improve efficiency and reduce emission output of two-stroke engines. However, simultaneous introduction of fuel and release of exhaust gases leads to a loss of unburned hydrocarbons (UHC), and ultimately higher emissions output than comparable four-stroke engines. This problem is perpetuated because two-stroke engine fuel normally consists of a mixture of gasoline and a petroleum lubricant. The latter material has a higher average molar mass, and is therefore less efficiently oxidized during the combustion process than the lighter gasoline.

A positive aspect of the two-stroke engine design is that combustion takes place at a lower temperature than a conventional four-stroke engine. The lower combustion temperature leads to an exhaust gas composition that is relatively low in nitric oxide (NO<sub>x</sub>) emissions, but high in carbon monoxide (CO) and unburned hydrocarbons (UHC).

Pre-competition emission testing was performed using a crankshaft mounted Land & Sea DYNOMite dynamometer. Learning that untreated HC emissions of the stock 600-SDI engine were significantly higher than the figures of past CSC winners, the team's first step to reducing emissions was the addition of a catalyst. For this, UW-P contacted Tikka Race (TR), a company that specializes in fitting carbureted two-stroke and four-stroke engines with pre-burn catalyst systems. TR supplied a custom pre-burn catalyst and muffler system specifically designed for this engine's operating conditions. Three metal substrate three-way catalysts are used to reduce emissions.

The exhaust gas first passes through a muffler that preheats the catalysts. From here, the exhaust enters a Rhodium catalyst. This facilitates the reduction of the nitrogen oxides to maximize the formation of di-nitrogen. The exhaust gas is then passed over a second catalyst made of Palladium. This part of the catalyst reduces the residual hydrocarbon and carbon monoxide gas remaining after passing through the first Rhodium catalyst. A 100 cells per square inch (CPSI) catalyst (catalyst 3) operates in parallel with a 400 CPSI catalyst (catalyst 2), that operates in series with a 300 CPSI catalyst (catalyst 1). Upon engine startup, catalyst three lights within the first two minutes. In the following two to four minutes, catalyst 1 and 2 will light. As shown in Table 4, installing of the pre-burn catalytic after-treatment initially reduced HC emissions by 80 %. Optimizing the fuel injection system through more tuning will result in even greater reductions in emissions.

**Table 5: Emissions data during dynamometer testing.**

Emissions (ppm)					
Mode Point	Speed (RPM)	Untreated		With TCS Catalyst	
		HC	NO <sub>x</sub>	HC	NO <sub>x</sub>
<b>1</b>	<b>8000</b>	5000	530	1000	70
<b>5</b>	<b>1500</b>	4500	58	1	30

Optimizing the efficiency of a three-way catalyst requires the entering exhaust gas to oscillate between slightly rich and slightly lean. Since the pre-burn TR catalyst is designed for carbureted engines, it does not depend on the fuel system to create this scenario. As shown in Figure 7, the catalyst itself alternates between a low

temperature of 676°C and a high temperature of 900°C, creating a slightly rich and slightly lean oscillation pattern [20].

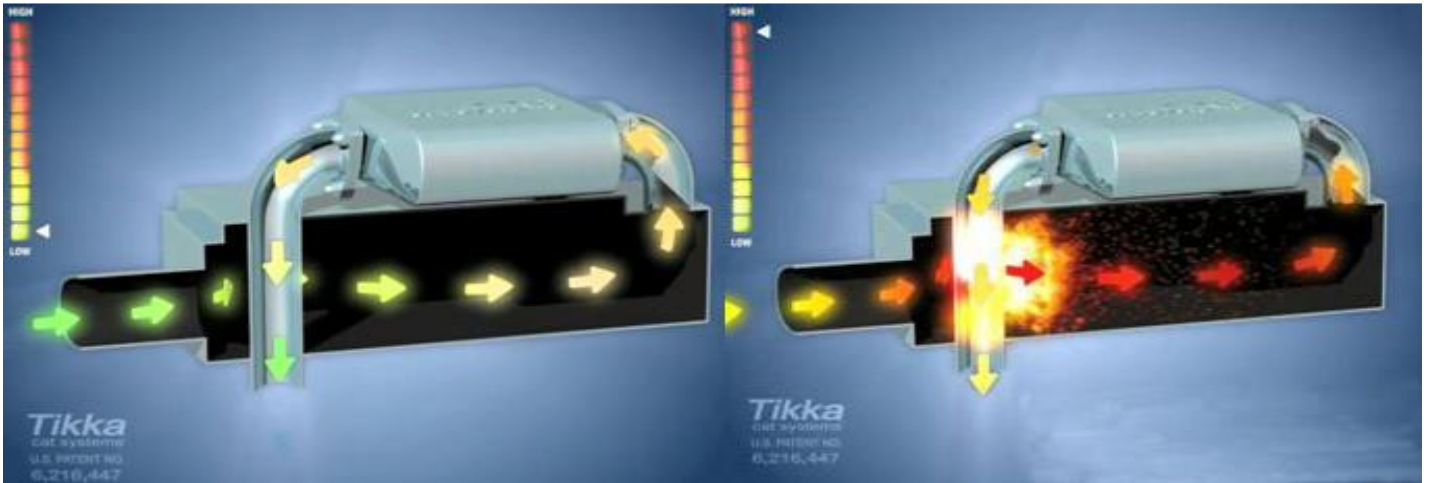

Figure 8: TR catalyst operating at low temperature (left), and high temperature (right).

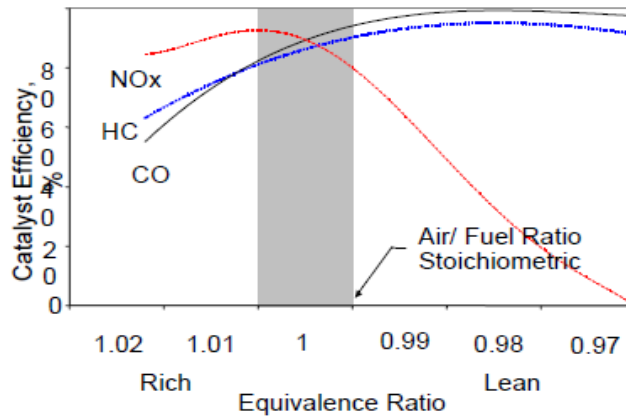

Figure 9: Conversion efficiency of NO<sub>x</sub>, CO, and HC for a three-way catalytic converter as a function of exhaust gas air/fuel ratio operating on gasoline [21].

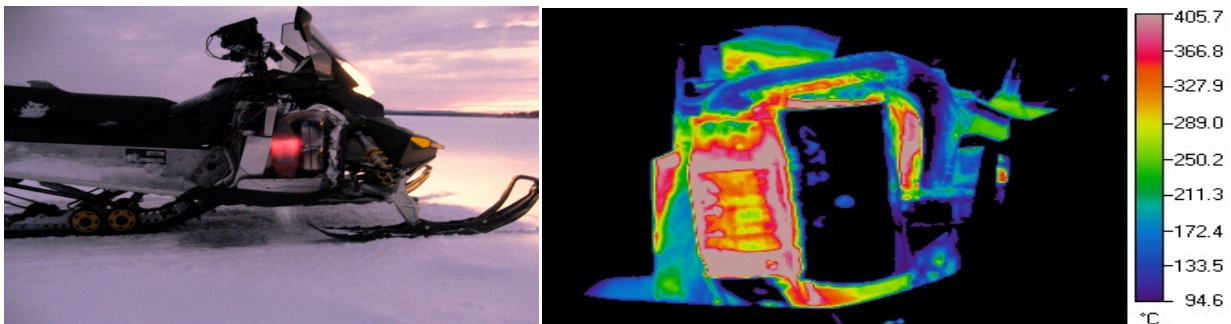

Figure 10(left): Trail testing of the pre-burn catalyst system. Right: Thermal image of pre-burn catalyst during UW-P emissions testing.

## NOISE

Once an initial sound clip of the snowmobile at 6000 RPM was recorded on the loudest side of the sled, sound testing was done in a controlled environment to ensure accuracy of both the equipment and the materials. Each test had a duration of one second at 1000 samples per second. Figure 9 shows a material testing procedure to test different materials.

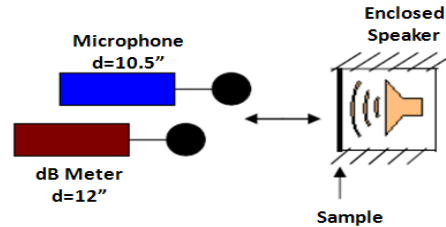

Figure 9: Schematic of the material-sample test configuration.

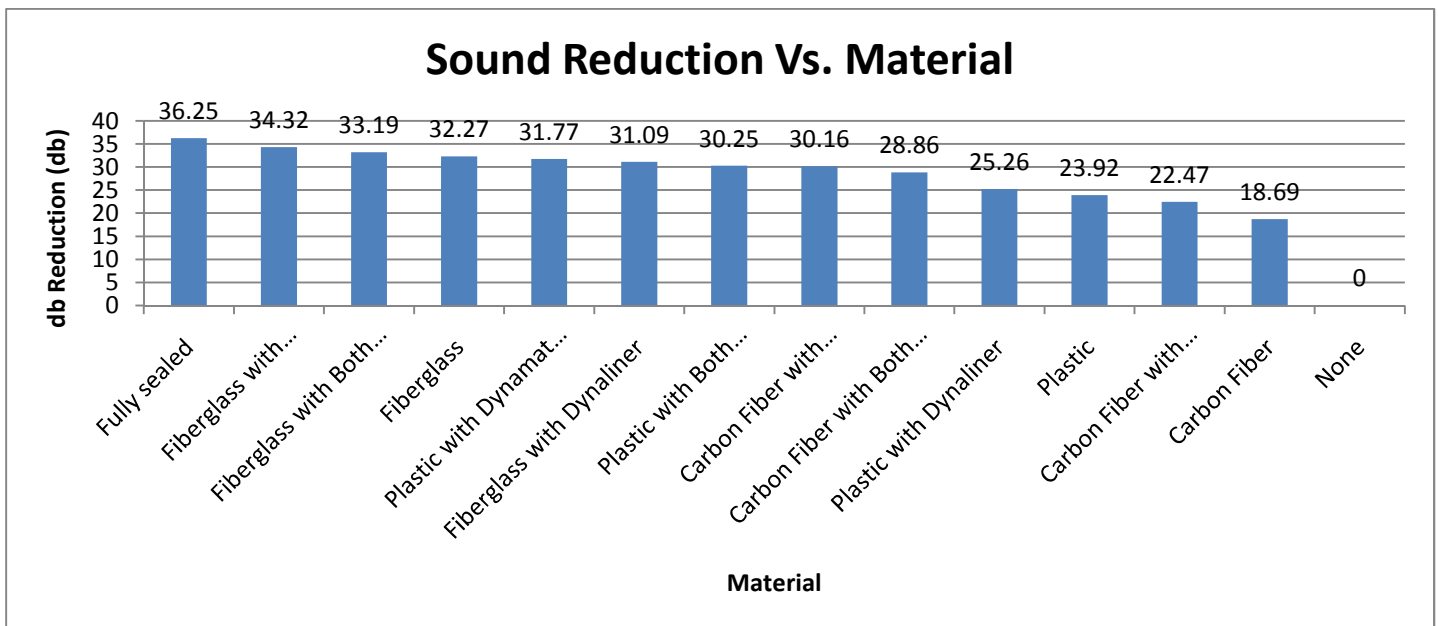

Figure 10: Graph showing sound reduction relative to material.

Noting the results of this controlled test, UW-P chose to use fiberglass and plastic panels with Dynamat Extreme material on them, as these two options were the most practical for the team while reducing the most noise.

## COST ESTIMATE

Advancements in technology currently implemented in the automotive industry are finally making their way into the snowmobile and recreational vehicle industry. However, utilizing these advancements have continued to increase the cost of snowmobiles on a yearly basis. The Manufactures Suggested Retail Price (MSRP) for a stock 2010 Ski-Doo MX Z<sup>®</sup> Adrenaline<sup>™</sup> Rotax<sup>®</sup> 600 H.O. E-TEC is \$9,699.99. After the modifications the

Wisconsin-Platteville Team did the MSRP would be raised \$5,123.25 to a total of \$14823.24. Justification on the increase in the MSRP is shown in its flex fuel capability, chassis modifications to improve safety, driveline modifications to greatly improve efficiency, and additional components used to reduce emission and noise outputs.

## CONCLUSION

Through exhaustive research and development, the University of Wisconsin-Platteville has produced a performance oriented and environmental friendly snowmobile that can run on any ethanol blended fuel between E20 and E29. Keeping consumer performance requirements in mind throughout the design process required the team to develop innovative solutions that would both maintain the manufacturer's performance and durability requirements while surpassing the EPA's 2012 emission standards. Thanks to the addition of a preburn catalyst system the, 2008 SnowGoer Magazine Snowmobile of the year can now tour all environments without damaging them [22].

## REFERENCES

1. International Snowmobile Manufacture Association (ISMA), [http://www.snowmobile.org/pr\\_snowfacts.asp](http://www.snowmobile.org/pr_snowfacts.asp).
2. Society of Automotive Engineers, Inc., The SAE Clean Snowmobile Challenge 2010 Rules, 2009. <http://students.sae.org/competitions/snowmobile/rules/>.
3. Recreated from Code of Federal Regulations, 40CFR Part 1051.103
4. Lela C., White J., "Laboratory Testing of Snowmobile Emissions". Report Number SwRI 08.05486, Southwest Research Institute, San Antonio, July 2002.
5. United States Environmental Protection Agency; 40 CFR Parts 1051.103 and 1065, February 28, 2006.
6. United States Department of the Interior National Park Service, Special Regulations; Areas of the National Park System, Final Rule. 36 CFR Part 7, November 10, 2004.
7. Delmont, Joe. "Snowmobile Manufactures Increase Promotion After Dismal 2007 Sales Season". June 1, 2007. Dealernews. <http://www.dealernews.com/dealernews/article/articleDetail.jsp?id=436247&pageID=1&sk=&date>.
8. Society of Automotive Engineers, Inc., The SAE Clean Snowmobile Challenge Results 2002. <http://students.sae.org/competitions/snowmobile/results/>.
9. Society of Automotive Engineers, Inc., The SAE Clean Snowmobile Challenge Results 2003. <http://students.sae.org/competitions/snowmobile/results/>.
10. Society of Automotive Engineers, Inc., The SAE Clean Snowmobile Challenge Results 2004. <http://students.sae.org/competitions/snowmobile/results/>.
11. Society of Automotive Engineers, Inc., The SAE Clean Snowmobile Challenge Results 2005. <http://students.sae.org/competitions/snowmobile/results/>.

12. Society of Automotive Engineers, Inc., The SAE Clean Snowmobile Challenge Results 2006.  
<http://students.sae.org/competitions/snowmobile/results/>.
13. Society of Automotive Engineers, Inc., The SAE Clean Snowmobile Challenge Results 2007.  
<http://students.sae.org/competitions/snowmobile/results/>.
14. Society of Automotive Engineers, Inc., The SAE Clean Snowmobile Challenge Results 2008.  
<http://students.sae.org/competitions/snowmobile/results/>.
15. Lela, C., White, J., Haines, H., and Sacklin, J. "Laboratory Testing of Snowmobile Emissions: Southwest Research Institute." Report number SwRI 08.05486. July 2002. Montana Department of Environmental Quality. Helena, Montana, and National Park Service, Yellowstone National Park, Wyoming.
16. Morikawa K., Takimoto H., Ogi T., "A Study of Direct Fuel Injection Two-Stroke Engine for High Specific Power Output and High Engine Speed", SAE Paper 1999-01-3288 / JSAE 9938043, 1999.
17. "What's New For 2008 Ski-Doo!". Alaska Mining and Driving Supply.  
<http://akmining.com/snow/skinew.htm>
18. <http://www.fuelpub.com/online/article.jsp?siteSection=4&id=628&pageNum=1>
19. Boondocker Performance, website, [www.boondocker.com](http://www.boondocker.com)
20. Tikka, M., Tikka Racing, personal communication, January, 2010.
21. Heywood, J.B. "Internal Combustion Engine Fundamentals." McGraw Hill, Inc 1988.
22. "2008 Snowmobile Of The Year". SnowGoer Magazine.  
<http://www.snowgoer.com/output.cfm?id=1295281>

## **CONTACT INFORMATION**

Dr. David N. Kunz  
Faculty Advisor  
kunzd@uwplatt.edu

## **ACKNOWLEDGMENTS**

The University of Wisconsin-Platteville Clean Snowmobile Challenge Team would like to thank our sponsors: Renewable Fuels Association, Wisconsin Bio-Industry Alliance, University Of Wisconsin-Platteville SUFAC, Edgewater Marine, Ski-Doo, AMSOIL, Digatron, Millennium Technologies, Motosports Factory, Hiperfax, Retrax, Kohn's Auto Body, Fastenal, Goodwin Performance, HMK, Land and Sea, Emission Systems, Signs-to-Go, UW-P Mechanical Engineering Dept., UW-P Electrical Engineering Dept., R & R Trailers, Association of Wisconsin Snowmobile Clubs, Tikka Race, FXR, Pete Nydahl Crank & Machining, and many others who made this project possible.